

LEDs

SMD 0805 Reverse Mount - Red

HL-9664

Package Configuration

| Descriptions: |
|--------------------------------|
| Emitting Color: Red |
| Device Outline: 2.0x1.25x0.8mm |
| Lens Type: Water Clear |

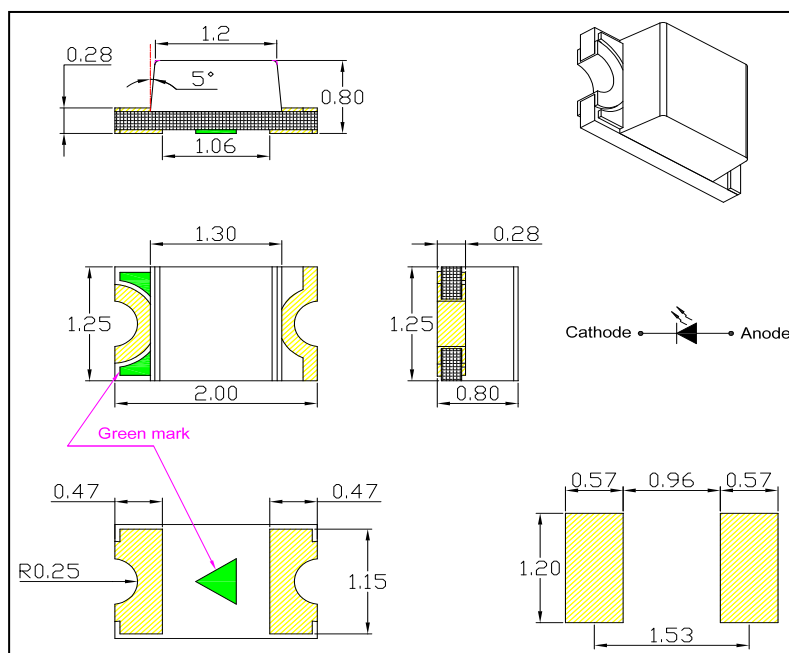

Absolute Maximum Ratings (Ta=25°C)

| Parameter | Max. | Unit. |
|---|---------------------|-------|
| Peak Forward Current (1/10 Duty Cycle, 0.1ms Pulse Width) | 100 | mA |
| Continuous Forward Current | 20 | mA |
| Reverse Voltage | 5 | V |
| Operating Temperature Range | -40 °C to +85°C | |
| Storage Temperature Range | -40 °C to +100°C | |
| Lead Soldering Temperature[4mm(.157") From Body] | 250°C for 5 Seconds | |

Electrical and optical characteristics

| Parameter | Symbol | Min. | Typ. | Max. | Unit. | Test Condition |
|--------------------|--------|------|------|------|-------|----------------|
| Luminous Intensity | IV | - | 140 | - | mcd | If=20mA |
| Viewing Angle | 2θ 1/2 | - | 130 | - | deg. | |
| Wavelength | Δd | - | 625 | - | nm | |